

6. QUEEN

LESS BULKY - SHORTER
 EASIER USAGE
 EASIER INSTALLATION
 CHEAPER

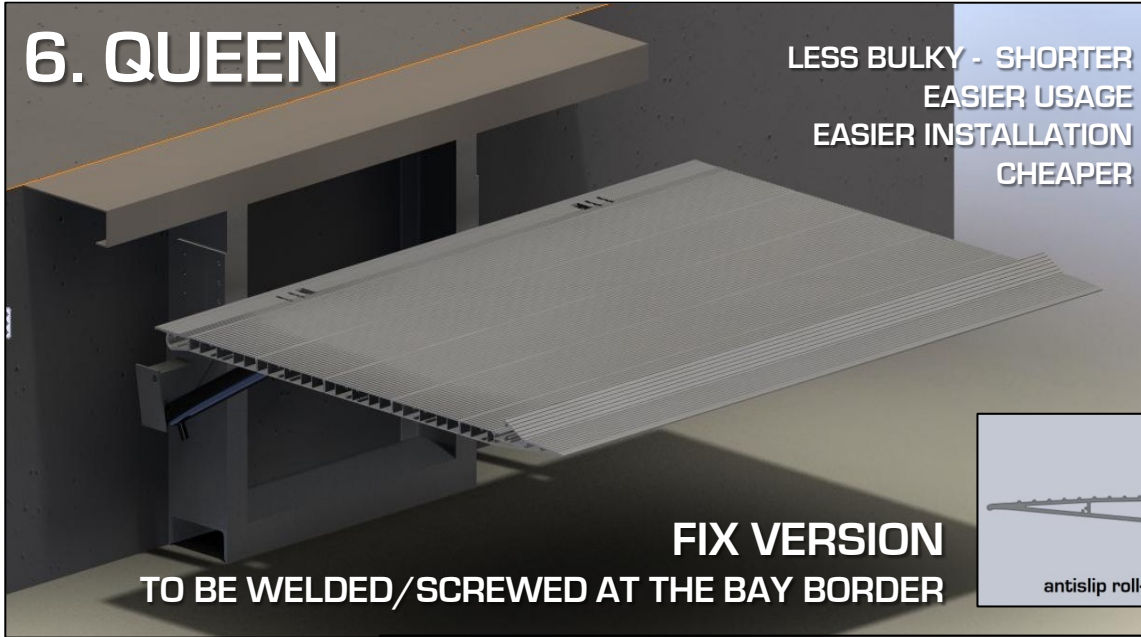

FIX VERSION

TO BE WELDED/SCREWED AT THE BAY BORDER

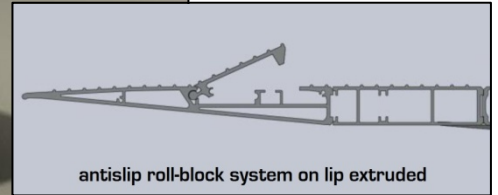

MOBILE VERSION TO BE MOVED BY FORKLIFT

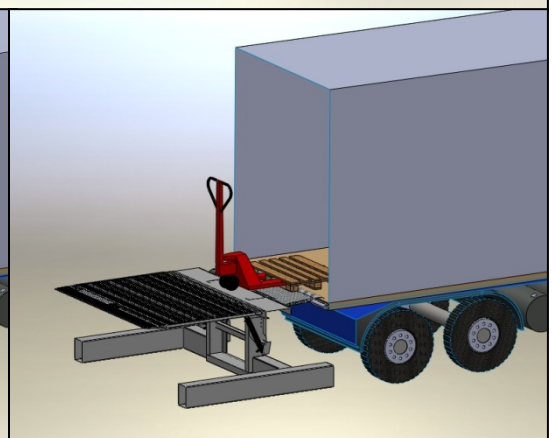
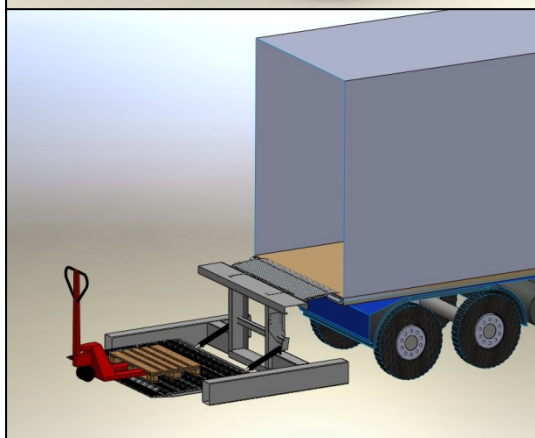
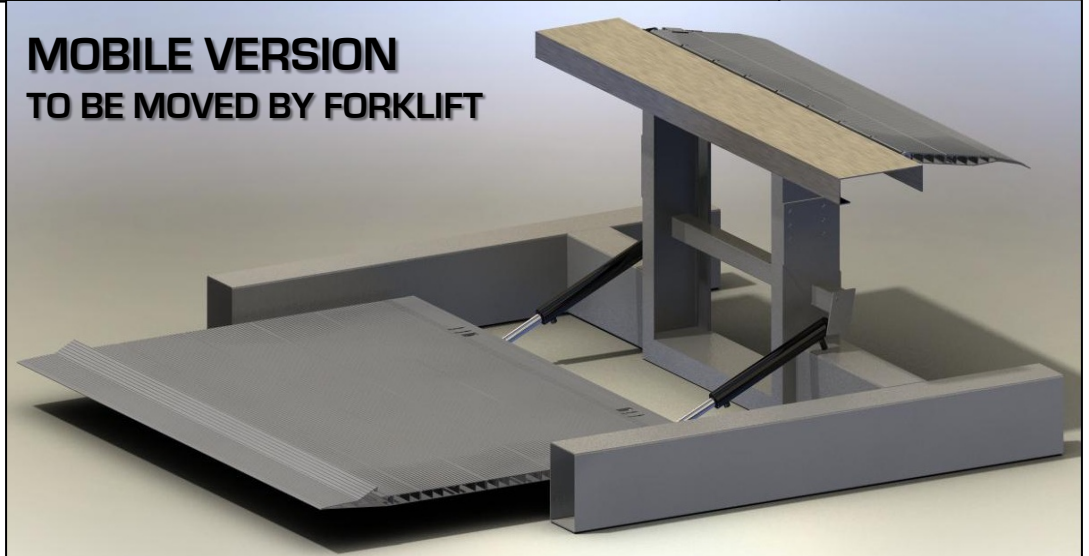

- DETAILS:**
 Hydraulic lifting platform for loading/unloading in high gradient situations (e.g. container/groundfloor)
 - Aluminum 6060 alloy extruded with 2000kg capacity particular lip shape with anti-slip roll-block
 - Supporting profile in galvanized steel (if requested the connection profile between backlip and plate can be in stainless steel)
 - Couple of plate lifting oil pistons
 - Hydraulic control unit connected to rubber feet activation buttons directly on the plate
 - Aluminum connection lip model CR40B 2000x400 with 4000kg capacity

AVAILABLE FOR:

1000KG
2000KG
3000KG

CODE	X (mm)	Y (mm)	DRIVE (mm)	WEIGHT (kg)
QN	2400	1800	0-1000/1400	530
QNM	2400	1800	0-1000/1400	730
PPTQN	Lateral anti-falling handrails			